

Argonaut V ADSP<sup>2</sup> Installation  
Low Power Board  
Catalog Number 70-11

**This document describes procedures that could result in voiding of the warranty of your radio.**

If these procedures are not precisely and properly carried out, it could result in a radio that does not work or is damaged.

Furthermore, while reasonable efforts have been made to assure the accuracy of this information, it is possible that there are some errors, or that your radio is of a slightly different version than the one used for testing and thus, differences may exist. You are expected to take total responsibility for your own actions.

It is assumed that anyone following suggestions made in this document is already thoroughly familiar with the technologies and techniques involved and possesses the necessary skill and knowledge to make their own judgment as to the appropriateness and validity of the information.

*If you choose to do the installation outlined, you do so at your own risk. You are solely responsible for any damage, voiding of warranty, or other harm that may come about by following these procedures. It is very strongly recommended that, if you maintain your own radio, you thoroughly familiarize yourself with the transceiver service manual. If you don't have one, get one!*

CAUTION: Soldering and desoldering of very small Surface Mount Components may be required to perform this installation
--

**IMPORTANT NOTE: Support for the ADSP<sup>2</sup> board will be provided by SGC exclusively by email. Please write to [sgc@sgcworld.com](mailto:sgc@sgcworld.com) for assistance if needed.**

## 1. Technical Specifications

Specification	Low Audio	High Audio
<b>Size</b>	1.7 X 1.475"	2.645 X 1.475"
<b>Weight</b>	0.6 oz	1.1 oz
<b>Audio Limits</b>		
<b>Min Input</b>	10 mv RMS	100 mv RMS
<b>Max Input</b>	150 mv RMS	5 volt RMS
<b>Max Output</b>	.5 v RMS	9 v RMS
<b>Power Output</b>		5 Watts RMS
<b>Current Consumption</b>		
<b>idle</b>	80 mA	110 mA
<b>full out</b>	80 mA	500 mA
	X1	X2
<b>Noise Reduction</b>	13 dB	26 dB
<b>Time Delay</b>	6.5 ms	13 ms
<b>Tone Rejection</b>	-50 dB	-65 dB
<b>Filters (3dB Bandwidth)</b>		
<b>Voice</b>	300-2100 Hz	
<b>CW Wide</b>	400-900 Hz	
<b>CW Narrow</b>	600-700 Hz	
<b>Out of Band Rejection</b>	-45 dB	

SGC Inc. SGC Building, 13737 SE 26th St. Box 3526 Bellevue, WA. 98009 USA  
 Fax: 425-746-6384, Tel: 425-746-6310 or 1-800-259-7331  
 E-mail: [sgc@sgcworld.com](mailto:sgc@sgcworld.com) • World Wide Web: [www.sgcworld.com](http://www.sgcworld.com)  
 ©April 2003 SGC Inc



Argonaut V ADSP<sup>2</sup> Installation  
Low Power Board  
Catalog Number 70-11

## 2. Preparation

The ADSP<sup>2</sup> installation provides you with an unprecedented ADSP capability, far beyond what you can find on most amateur radio transceivers.

Every possible effort has been made to provide you with a simple, easy to use product. One where you can concentrate on your communication and not on fiddling with knobs. SGC's ADSP<sup>2</sup> will give you years of service improving your ability to communicate.

- ***Prepare your work area***
  
- ***Assemble your tools and parts***

- ADSP<sup>2</sup> board
- ADSP<sup>2</sup> switch assembly
- Double-stick tape for mounting the board
- Tools for disassembling your transceiver
- soldering iron suitable for working with Surface Mount Devices

## 3. Install the ADSP<sup>2</sup> Board

- ***Open your transceiver***
  
- ***Remove the backing from the double-stick foam tape and attach the ADSP<sup>2</sup> assembly into a convenient location***

On the Argonaut V, the best place to locate the ADSP<sup>2</sup> board is on the main board as shown below:

# SGC

Argonaut V ADSP<sup>2</sup> Installation  
Low Power Board  
Catalog Number 70-11

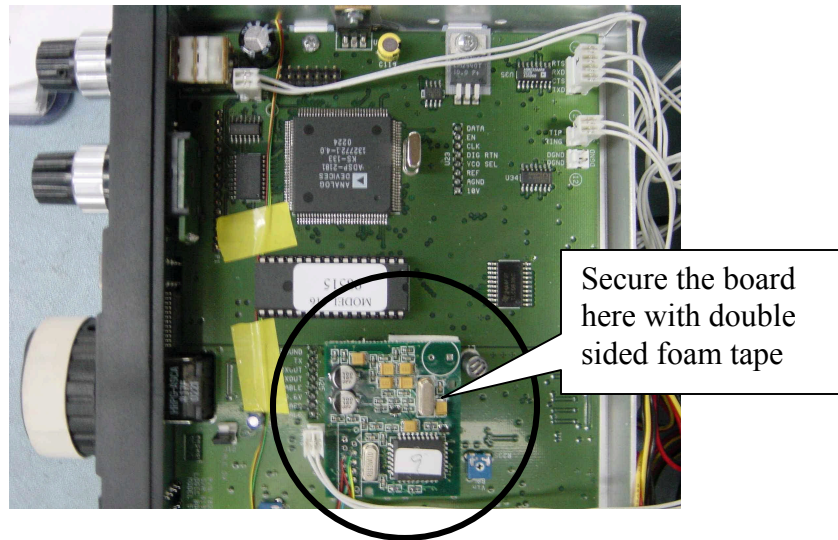

It is convenient to run the wires to the other side of the board through the gap between the panel and the board:

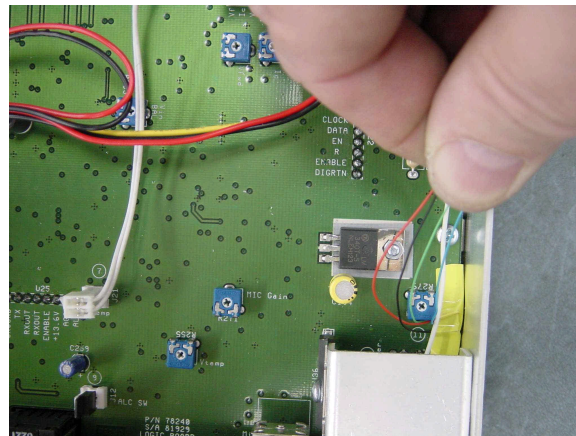

□ **Connect the ADSP<sup>2</sup> into the signal path**

The following connections will be made between the ADSP<sup>2</sup> board and the Argonaut V:

- Pin 7 to 12V DC, White wire
- Pin 9 to DC ground, Black wire
- Pin 8 to audio in to the ADSP<sup>2</sup>, Gray wire
- Pin 10 to the audio out from the ADSP<sup>2</sup>, Brown wire



Argonaut V ADSP<sup>2</sup> Installation  
Low Power Board  
Catalog Number 70-11

You will also need to make the following connections to the board from the momentary switches provided for switching ADSP modes and Filters:

- Pin 4 to the Yellow Wire
- Pin 5 to the Red Wire
- Pin 6 to the Black Wire

The picture below shows these connections:

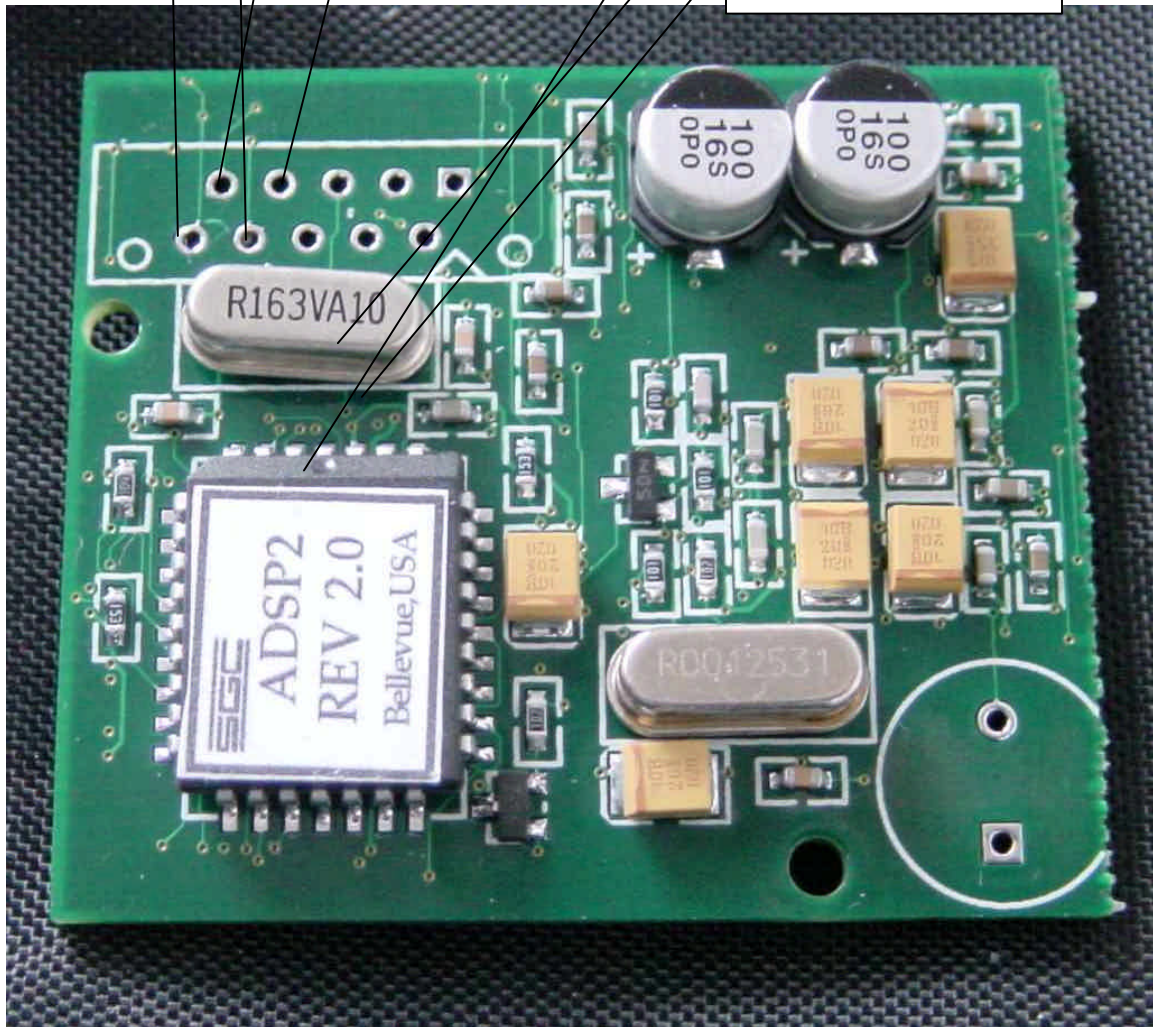
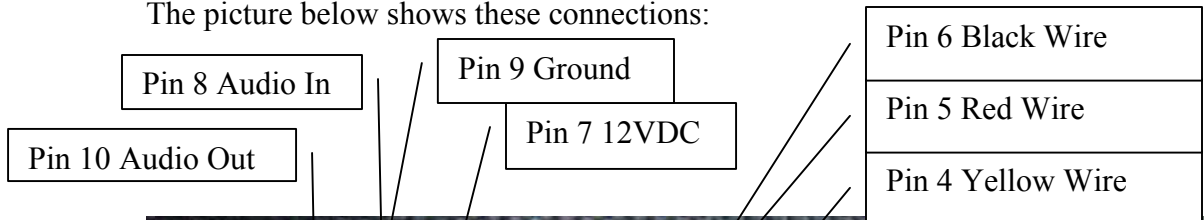

**SGC**  
Argonaut V ADSP<sup>2</sup> Installation  
Low Power Board  
Catalog Number 70-11

The audio path should be broken at the input to the audio amplifier just before the volume control. The only requirement at this point is that a minimum of 10 millivolts RMS and a maximum of 150 millivolts RMS will appear at this point when using the Low Power version of the ADSP<sup>2</sup>. Normally, there is a capacitor at this point (0.1 uf is a typical value) to couple the stages together. Remove this capacitor and connect the ADSP<sup>2</sup> board in its place. The board has coupling capacitors on its input and output.

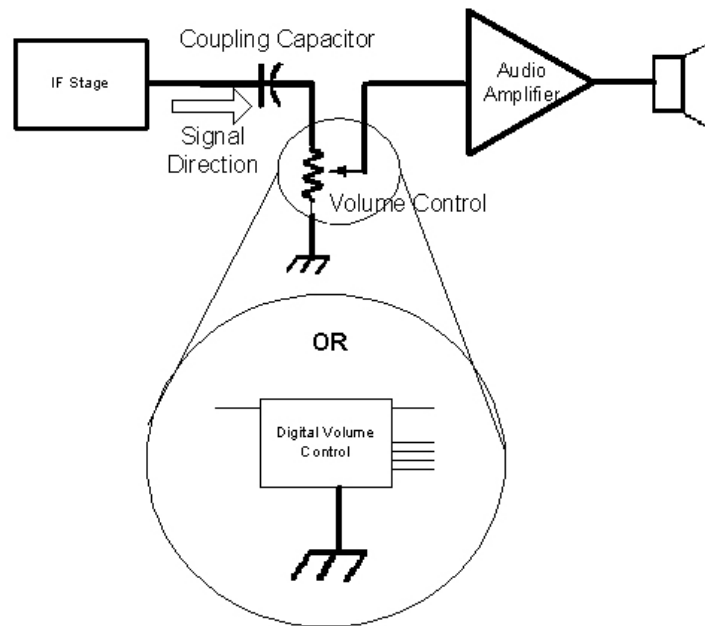

First, capacitor C87 is removed and the board is installed across the connections where it was. The Argonaut schematic shows it like this:

# SGC

## Argonaut V ADSP<sup>2</sup> Installation Low Power Board Catalog Number 70-11

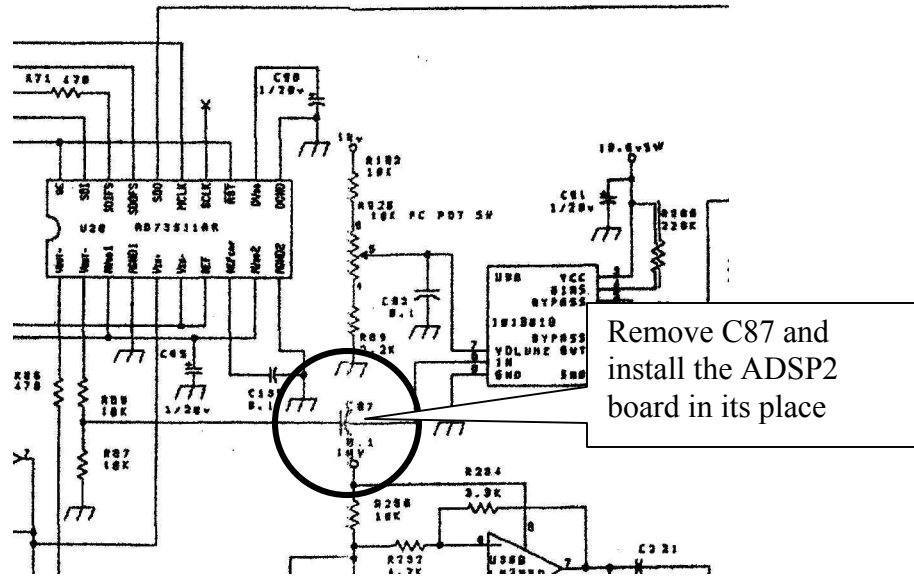

Connect the signal path as shown in the diagram. Your installation should look like this:

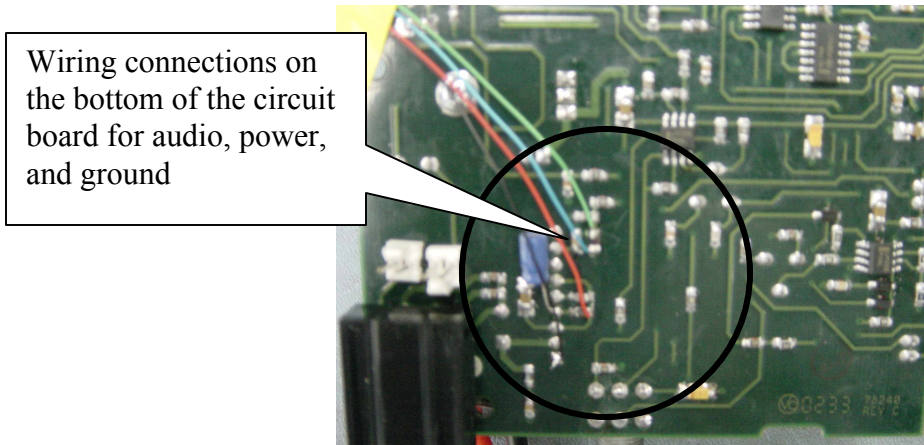

12 VDC can be taken from any point where it is convenient and the ground can be connected to any convenient point that is connected to the chassis ground. Connect the 12 VDC and GND wires from the ADSP<sup>2</sup> board and connect them to the Argonaut's power supply. A convenient location is shown on the schematic below.



Argonaut V ADSP<sup>2</sup> Installation  
Low Power Board  
Catalog Number 70-11

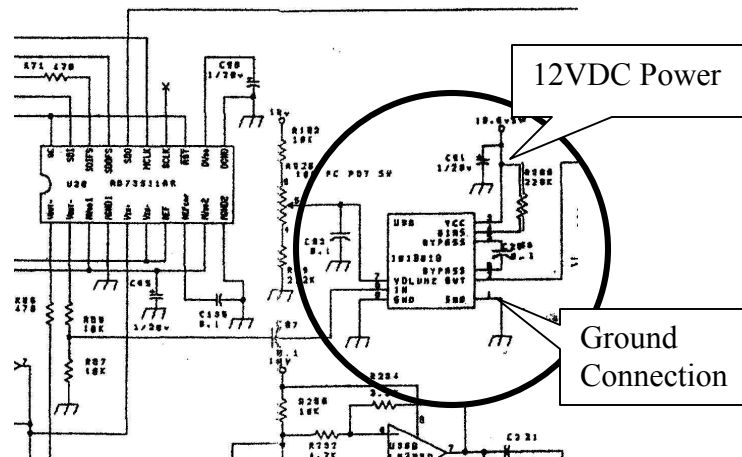

When complete, your installation should look like the installation picture above.:

- Route the ADSP<sup>2</sup> switch assembly out of the transceiver body***
- Connect the switch assembly to the switch wire connector**
- Reassemble the transceiver**

#### 4. Test your transceiver

The switch buttons are assigned to their functions according to the diagram below:

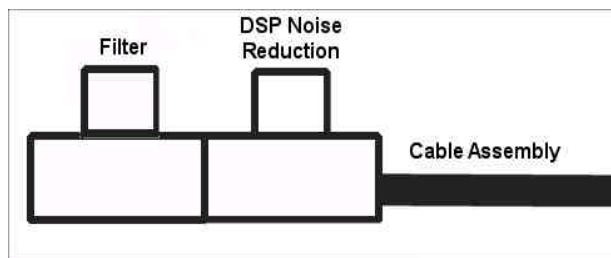

Each switch steps through its functions in order as shown below under testing.

**SGC**  
Argonaut V ADSP<sup>2</sup> Installation  
Low Power Board  
Catalog Number 70-11

□ **Testing the ADSP Functions**

- Press & Release the ADSP<sup>2</sup> Pushbutton for Noise Reduction X1
- Press & Release the ADSP<sup>2</sup> Pushbutton for Noise Reduction X2
- Press & Release the ADSP<sup>2</sup> Pushbutton for No Reduction
- Repeat several times to verify operation

□ **Testing the Filter Functions**

- Press & Release the Filter Pushbutton for the Voice Filter
- Press & Release the Filter Pushbutton for the Wide CW Filter
- Press & Release the Filter Pushbutton for the Narrow CW Filter
- Press & Release the Filter Pushbutton for No Filter
- Repeat several times to verify operation

## 5. Installing the Switches

The switches may be installed in any convenient location. The specific choice of switches was made to make it easy to mount on nearly any transceiver. Some people have chosen to install their switches on the side of the unit, others have preferred the top, and some on the front. Your specific installation will determine what the best location is. We found it convenient to put the switches at the right of the front panel as shown below:







Argonaut V ADSP<sup>2</sup> Installation  
Low Power Board  
Catalog Number 70-11

SGC welcomes any suggestions regarding these switches to improve installation and operation.

**CAUTION:** Overdriving the ADSP<sup>2</sup> module may cause distortion. Backing off the level of the input signal will avoid it.

**SPECIAL NOTE:** SGC is constantly seeking to improve the accuracy and ease of use of its technical documentation. Any suggestions for improving this document will be much appreciated by SGC Management.



Argonaut V ADSP<sup>2</sup> Installation  
Low Power Board  
Catalog Number 70-11

SGC Inc. SGC Building, 13737 SE 26th St. Box 3526 Bellevue, WA. 98009 USA  
Fax: 425-746-6384, Tel: 425-746-6310 or 1-800-259-7331  
E-mail: [sgc@sgcworld.com](mailto:sgc@sgcworld.com) • World Wide Web: [www.sgcworld.com](http://www.sgcworld.com)  
©April 2003 SGC Inc



Argonaut V ADSP<sup>2</sup> Installation  
Low Power Board  
Catalog Number 70-11

SGC Inc. SGC Building, 13737 SE 26th St. Box 3526 Bellevue, WA. 98009 USA  
Fax: 425-746-6384, Tel: 425-746-6310 or 1-800-259-7331  
E-mail: [sgc@sgcworld.com](mailto:sgc@sgcworld.com) • World Wide Web: [www.sgcworld.com](http://www.sgcworld.com)  
©April 2003 SGC Inc



Argonaut V ADSP<sup>2</sup> Installation  
Low Power Board  
Catalog Number 70-11

SGC Inc. SGC Building, 13737 SE 26th St. Box 3526 Bellevue, WA. 98009 USA  
Fax: 425-746-6384, Tel: 425-746-6310 or 1-800-259-7331  
E-mail: [sgc@sgcworld.com](mailto:sgc@sgcworld.com) • World Wide Web: [www.sgcworld.com](http://www.sgcworld.com)  
©April 2003 SGC Inc